



## Submittal Data

### Pressure Battery™ Expansion Tank



Project Name: \_\_\_\_\_

Contractor: \_\_\_\_\_

Engineer: \_\_\_\_\_

Order Number: \_\_\_\_\_

Additional Information: \_\_\_\_\_

## Specifications and Dimensions

Shell: High Density Polyethylene (ASTM PE4710, ISO PE100); factory butt-fused for leak proof assembly

Bladder: Nitrile (NBR)

Bladder Retaining/Screws: Steel/Stainless steel (air-side only; no fluid-to-metal contact)

Max. Fluid Temperature: 110° F  
Max. Pressure: 100 psig

A		B		C		D		E
in	mm	in	mm	in	mm	in	mm	
8	71	14-5/8	371	13-1/2	343	7-1/8	181	1-1/4 SOCKET FUSION FEMALE

## Approved Antifreeze

Ethanol  
Methanol  
Propylene Glycol  
Environol™

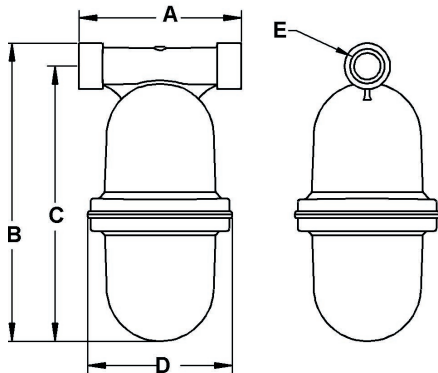

Tank Volume		Ship Weight	
Gallons	Liters	lbs	kg
.75	2.8	4	1.8

## Mounting

The *Pressure Battery™* can be installed in any position from horizontal to vertical, can be installed indoors or buried in the header pit, and for best performance should always be installed on the return side of the ground loop system prior to the circulator pump.

All dimensions and weights are approximate.

## Tank Acceptance Volume

Pressure Battery™ Expansion Tank Acceptance Volume

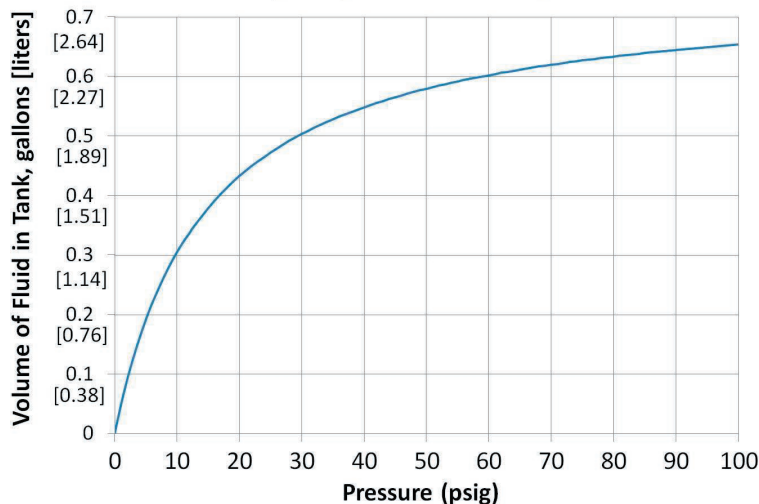

GEO-FLO PRODUCTS CORPORATION  
905 Williams Park Drive  
Bedford, IN 47421  
Phone: 812-275-8513 Fax: 812-275-8523  
www.geo-flo.com